

MATERIAL LIST / LISTE DE MATERIEL

(DESIGNATIONS OF PIECES IN IMPERIAL, DIMENSIONS IN MILLIMETERS UNLESS OTHERWISE SPECIFIED)
(DÉSIGNATIONS DES PIÈCES EN IMPÉRIAL, DIMENSIONS EN MILLIMÈTRE SAUF INDICATION CONTRAIRE)

ITEM NO.	DESCRIPTION	MATERIAL/MATERIEL	QTY/QTE	DRAWING/DESSIN NO. PART/PIECE NO.	WEIGHT/POIDS KG	WEIGHT/POIDS LBS
1	ROULEAU ANTICOLMATANT		1	BBRD625301445A5	18.9	41.5
2	SUPPORT DE ROULEAU		1	BBRBRC445-54	3.1	6.9
3	VIS AUTO-TARAUDEUSE		2	HABSLZINC005NC010	0.0	0.0
4	FIXATION EXTÉRIEURE		2	BBRCEB25	0.0	0.0

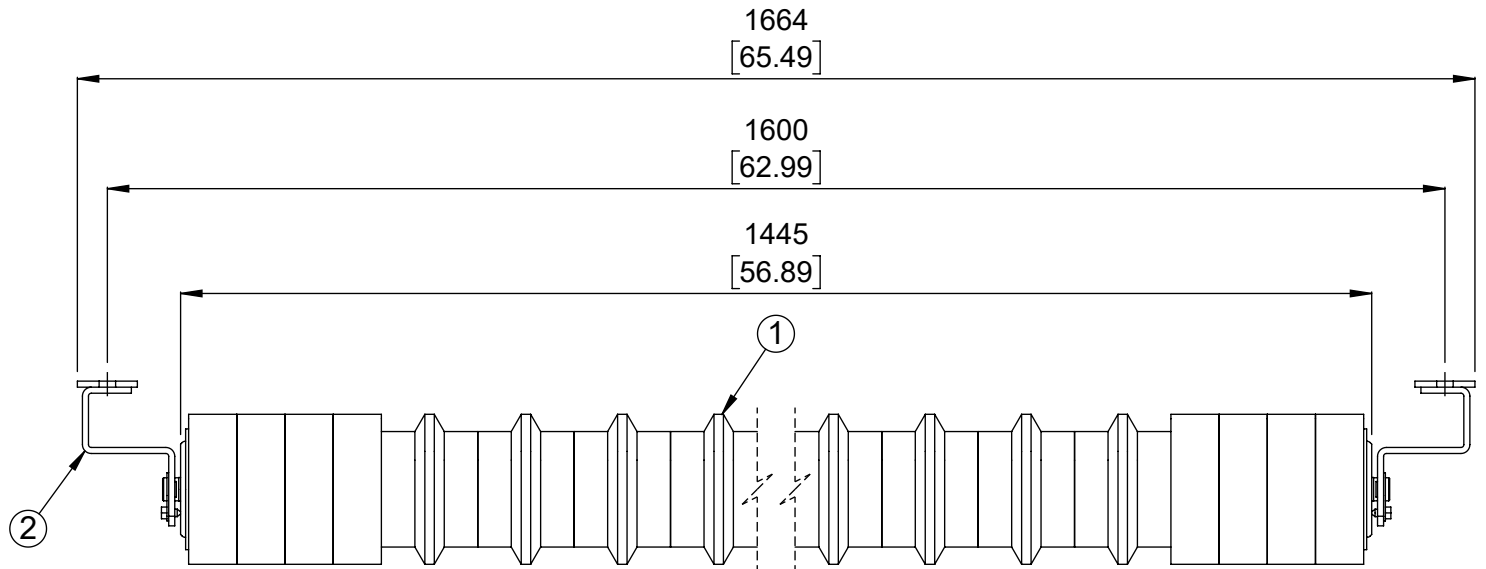
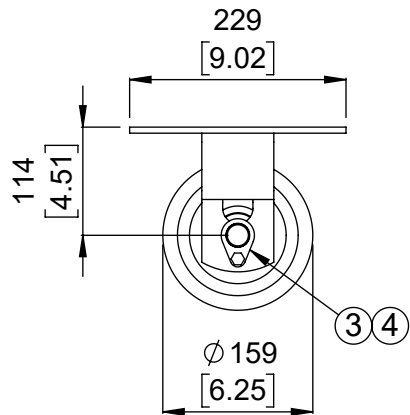
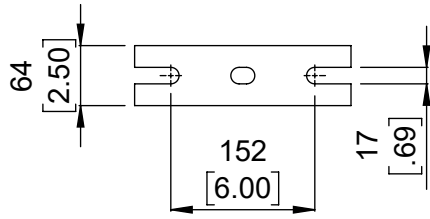

No.	REVISIONS	DATE	BY
0	ÉMIS POUR LA CONSTRUCTION	11-21-2024	AH

DO NOT SCALE
NE PAS PRENDRE À L'ÉCHELLE
DIMENSIONS ARE IN mm [INCHES]

SURFACE FINISH
✓

SURFACE

THIRD ANGLE PROJECTION PROJECTION TROISIÈME ANGLE

This drawing is the exclusive and confidential property of Continental Conveyor and Machine Works Ltd. / Ce dessin est la propriété confidentielle et exclusive de Convoyeur Continental et Usinage Ltee.

Drawn/Dessiné AH	Checked/Vérifié	Approved/Approuvé	Napaneé Job No./Contrat No.
Date (MM/DD/YYYY) 11-21-2024	Scale/Échelle 1:8	Weight/Poids Net 89.5 Lbs	Thetford Job No./Contrat No.
Identification No.			

continental CONTINENTAL CONVEYOR & MACHINE WORKS LTD.
CONVOYEUR CONTINENTAL & USINAGE LTÉE
THETFORD MINES, QUEBEC, CANADA
NAPANEE, ONTARIO, CANADA

STANDARD
STATION INFÉRIEURE PLAT ANTICOLMATANT
LARGEUR DE BANDE 54" ROULEAU Ø6-1/4" ARBRE Ø25mm CEMA D6

Format: Drawing No./Dessin No. **BB-41100-6-54** Revision **0**