

MATERIAL LIST / LISTE DE MATERIEL

(DESIGNATIONS OF PIECES IN IMPERIAL, DIMENSIONS IN MILLIMETERS UNLESS OTHERWISE SPECIFIED)
(DÉSIGNATIONS DES PIÈCES EN IMPÉRIAL, DIMENSIONS EN MILLIMÈTRE SAUF INDICATION CONTRAIRE)

ITEM NO.	DESCRIPTION	MATERIAL/MATERIEL	QTY/QTE	DRAWING/DESSIN NO. PART/PIECE NO.	WEIGHT/POIDS KG	WEIGHT/POIDS LBS
1	ROULEAU AMORTISSEUR		1	BBIR625300835A5	23.2	51.1
2	SUPPORT DE ROULEAU		2	BBFCST445	3.0	6.7
3	FIXATION EXTÉRIEURE		2	BBRCEB25	0.0	0.0
4	VIS AUTO-TARAUDEUSE		2	HABSLZINC005NC010	0.0	0.0

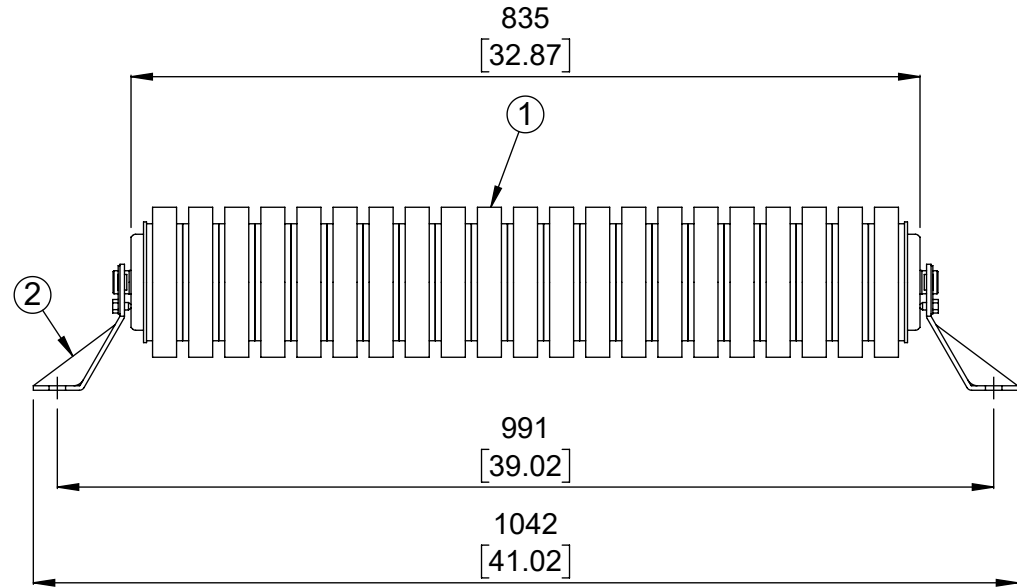
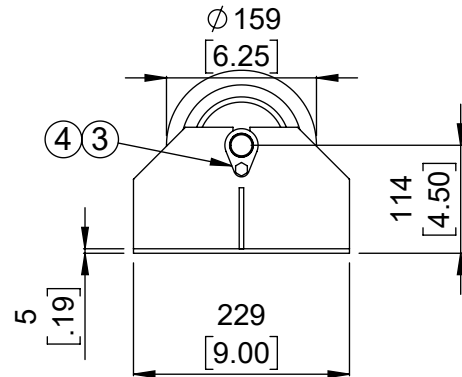
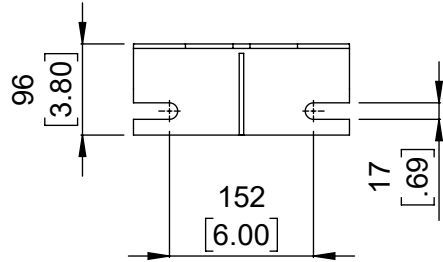

No.	REVISIONS	DATE	BY
0	ÉMIS POUR LA CONSTRUCTION	12-05-2024	AH

DO NOT SCALE
NE PAS PRENDRE À L'ÉCHELLE
DIMENSIONS ARE IN mm [INCHES]

SURFACE FINISH
✓

SURFACE

THIRD ANGLE PROJECTION
PROJECTION TROISIÈME ANGLE

This drawing is the exclusive and confidential property of Continental Conveyor and Machine Works Ltd. / Ce dessin est la propriété confidentielle et exclusive de Convoyeur Continental et Usinage Ltee.

Drawn/Dessiné AH	Checked/Vérifié	Approved/Approuvé	Napanee Job No./Contrat No.
Date (MM-DD-YYYY) 12-05-2024	Scale/Échelle 1:8	Weight/Poids Net 57.9 Lbs	Thetford Job No./Contrat No.
Identification No.			

continental CONTINENTAL CONVEYOR & MACHINE WORKS LTD.
CONVOYEUR CONTINENTAL & USINAGE LTEE

THETFORD MINES, QUEBEC, CANADA
NAPANEE, ONTARIO, CANADA

STANDARD

STATION SUPÉRIEURE AMORTISSEUR PLAT
LARGEUR DE BANDE 30" ROULEAU Ø6-1/4" ARBRE Ø25mm CEMA D6

Format: Drawing No./Dessin No. **BB-43000-6-30** Revision **0**