

# MATERIAL LIST / LISTE DE MATERIEL

(DESIGNATIONS OF PIECES IN IMPERIAL, DIMENSIONS IN MILLIMETERS UNLESS OTHERWISE SPECIFIED)  
(DÉSIGNATIONS DES PIÈCES EN IMPÉRIAL, DIMENSIONS EN MILLIMÈTRE SAUF INDICATION CONTRAIRE)

ITEM NO.	DESCRIPTION	MATERIAL/MATERIEL	QTY/QTE	DRAWING/DESSIN NO. PART/PIECE NO.	WEIGHT/POIDS KG	WEIGHT/POIDS LBS
1	ROULEAU ACIER		2	BBTR625250175A5	11.6	25.6
2	ROULEAU AMORTISSEUR		1	BBIR625250279A5	8.5	18.7
3	ROULEAU AMORTISSEUR		1	BBIR625300389A5	11.4	25.0
4	SUPPORT DE ROULEAU TYPE ALIMENTATEUR 20°		1	BBFR4042042	19.8	43.6
5	FIXATION EXTÉRIEURE		4	BBRCEB25	0.0	0.0
6	VIS AUTO-TARAUDEUSE		4	HABSLZINC005NC010	0.0	0.0
7	FIXATION INTÉRIEURE		2	BBRCCB20	0.0	0.0

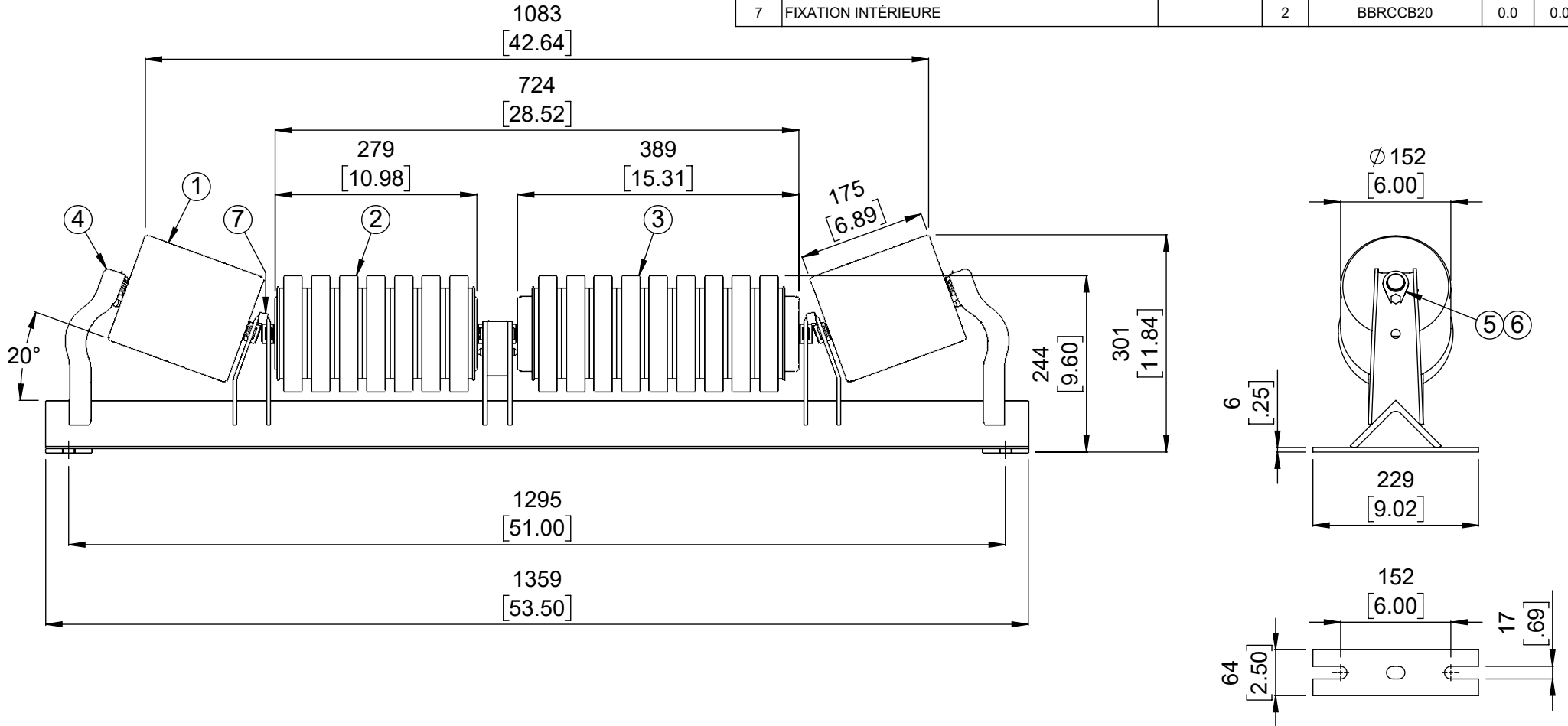

No.	REVISIONS	DATE	BY
0	ÉMIS POUR LA CONSTRUCTION	12-05-2024	AH

DO NOT SCALE  
NE PAS PRENDRE À L'ÉCHELLE

DIMENSIONS ARE IN mm [INCHES]

SURFACE FINISH

THIRD ANGLE PROJECTION PROJECTION TROISIEME ANGLE

SURFACE

This drawing is the exclusive and confidential property of Continental Conveyor and Machine Works Ltd.

Ce dessin est la propriété confidentielle et exclusive de Convoyeur Continental et Usinage Ltee.

Drawn/Dessiné: AH

Checked/Vérifié:

Approved/Approuvé:

Napinee Job No./Contrat No.:

Date (MM-DD-YYYY): 12-05-2024

Scale/Échelle: 1:8

Weight/Poids Net: 113.2 Lbs

Thetford Job No./Contrat No.:

Identification No.:

CONTINENTAL CONVEYOR & MACHINE WORKS LTD.

CONVOYEUR CONTINENTAL & USINAGE L'ÉE

THETFORD MINES, QUEBEC, CANADA  
NAPANEE, ONTARIO, CANADA

**STANDARD**

STATION SUPÉRIEURE, TYPE ALIMENTATEUR, AUGE 20°  
LARGEUR DE BANDE 42" ROULEAU Ø6-1/4" ARBRE Ø25mm CEMA D6

Format: Drawing No./Dessin No. **BB-43420-6-42** Revision **0**