

MATERIAL LIST / LISTE DE MATERIEL

(DESIGNATIONS OF PIECES IN IMPERIAL, DIMENSIONS IN MILLIMETERS UNLESS OTHERWISE SPECIFIED)
(DÉSIGNATIONS DES PIÈCES EN IMPÉRIAL, DIMENSIONS EN MILLIMÈTRE SAUF INDICATION CONTRAIRE)

ITEM NO.	DESCRIPTION	MATERIAL/MATERIEL	QTY/QTE	DRAWING/DESSIN NO. PART/PIECE NO.	WEIGHT/POIDS KG	WEIGHT/POIDS LBS
1	ROULEAU ACIER		3	BBTR525250541A6SC	40.8	89.7
2	SUPPORT DE ROULEAU 20°		1	BBFR40D2060	26.4	58.0
3	FIXATION EXTÉRIEURE		2	BBRCEB25	0.0	0.0
4	VIS AUTO-TARAUDEUSE		2	HABSLZINC005NC010	0.0	0.0
5	FIXATION INTÉRIEURE		2	BBRCCB20	0.0	0.0

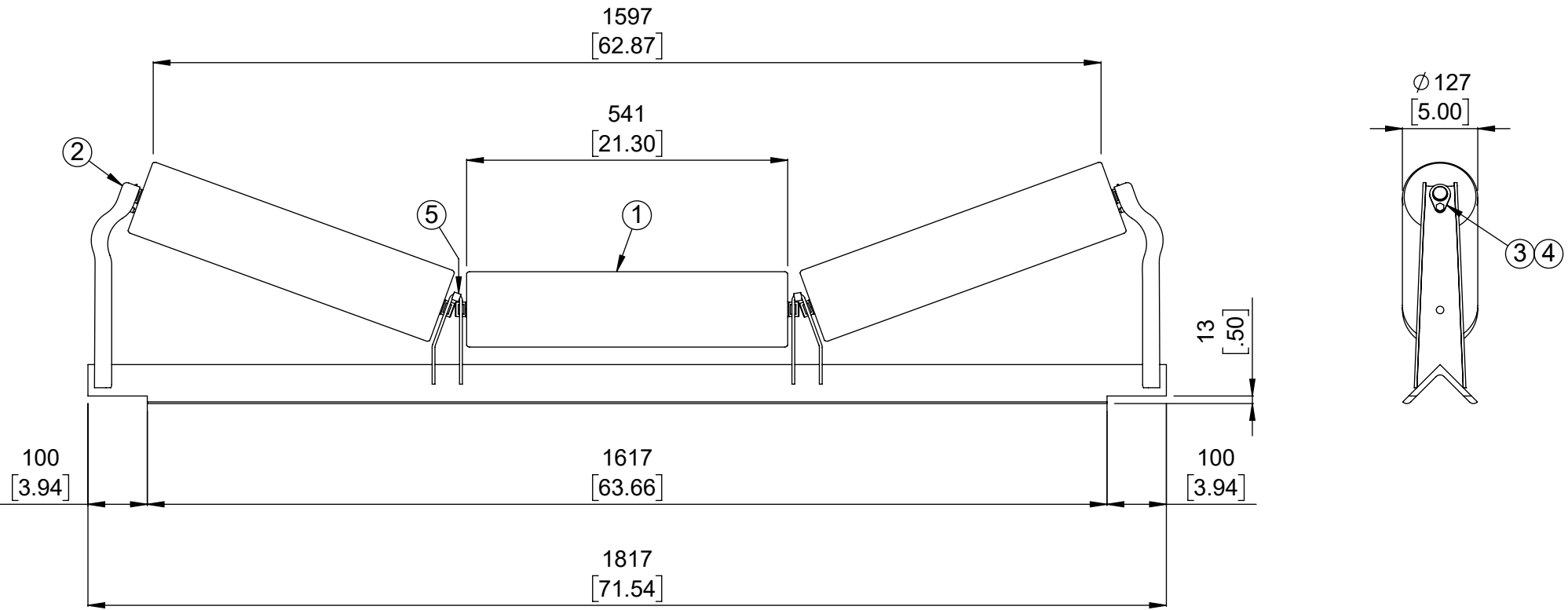

No.	REVISIONS	DATE	BY
0	ÉMIS POUR LA CONSTRUCTION	10-18-2024	AH

DO NOT SCALE
NE PAS PRENDRE À L'ÉCHELLE
DIMENSIONS ARE IN mm [INCHES]

SURFACE FINISH
✓

SURFACE

THIRD ANGLE PROJECTION PROJECTION TROISIÈME ANGLE

This drawing is the exclusive and confidential property of Continental Conveyor and Machine Works Ltd. Ce dessin est la propriété confidentielle et exclusive de Convoyeur Continental et Usinage Ltee.

Drawn/Dessiné AH	Checked/Vérifié	Approved/Approuvé	Napinee Job No./Contrat No.
Date (MM/DD/YYYY) 10-18-2024	Scale/Échelle 1:10	Weight/Poids Net 147.8 Lbs	Thetford Job No./Contrat No.
Identification No.			

continental CONTINENTAL CONVEYOR & MACHINE WORKS LTD.
CONVOYEUR CONTINENTAL & USINAGE LTÉE

THETFORD MINES, QUEBEC, CANADA
NAPANEE, ONTARIO, CANADA

STANDARD

STATION SUPÉRIEURE, TYPE PESEUR, SANS PIED, AUGÉ 20°
LARGEUR DE BANDE 60" ROULEAU Ø5" ARBRE Ø25mm CEMA C5

Format: Drawing No./Dessin No. **BB-44D20-5-60** Revision **0**