

MATERIAL LIST / LISTE DE MATERIEL

(DESIGNATIONS OF PIECES IN IMPERIAL, DIMENSIONS IN MILLIMETERS UNLESS OTHERWISE SPECIFIED)
(DÉSIGNATIONS DES PIÈCES EN IMPÉRIAL, DIMENSIONS EN MILLIMÈTRE SAUF INDICATION CONTRAIRE)

ITEM NO.	DESCRIPTION	MATERIAL/MATERIEL	QTY/QTE	DRAWING/DESSIN NO. PART/PIECE NO.	WEIGHT/POIDS KG	WEIGHT/POIDS LBS
1	ROULEAU ACIER		2	BBTR520200175A4	6.5	14.4
2	ROULEAU AMORTISSEUR		1	BBIR520200541A5	10.7	23.6
3	ROULEAU AMORTISSEUR		1	BBIR520200279A5	5.7	12.4
4	SUPPORT DE ROULEAU, TYPE ALIMENTATEUR, 20°		1	BBFR3042048	18.6	40.9
5	FIXATION EXTÉRIEURE		4	BBRCEB20	0.0	0.0
6	VIS AUTO-TARAUDEUSE		4	HABSLZINC005NC010	0.0	0.0
7	FIXATION INTÉRIEURE		2	BBRCCB20	0.0	0.0

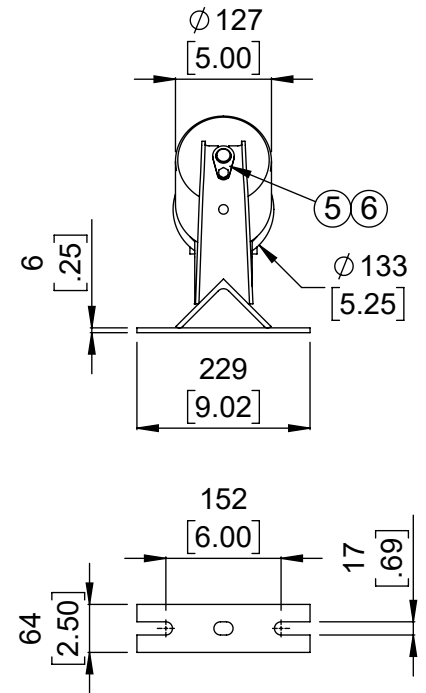
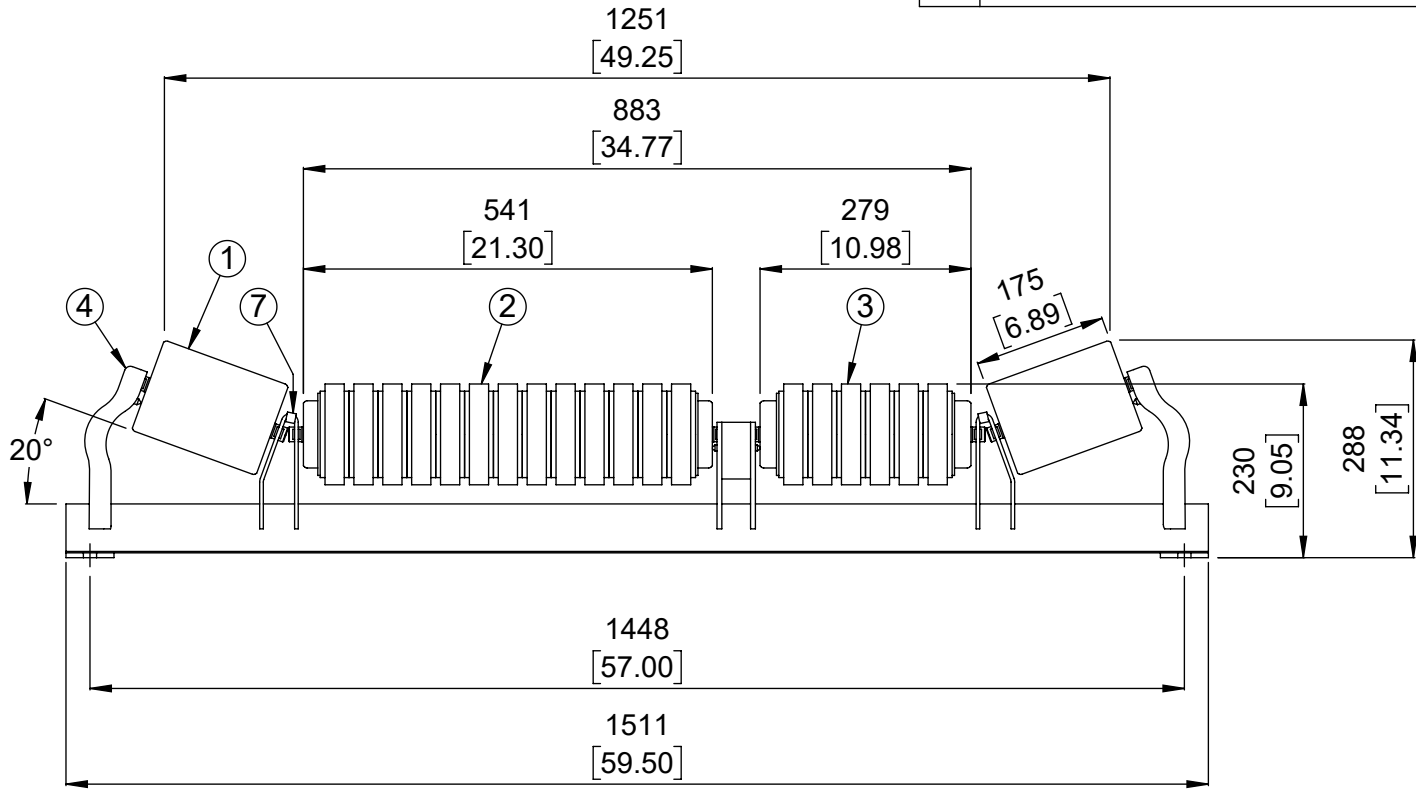

No.	REVISIONS	DATE	BY
0	ÉMIS POUR LA CONSTRUCTION	02-19-2025	AH

DO NOT SCALE
NE PAS PRENDRE À L'ÉCHELLE

DIMENSIONS ARE IN mm [INCHES]

SURFACE FINISH
✓

SURFACE

THIRD ANGLE PROJECTION
PROJECTION TROISIÈME ANGLE

This drawing is the exclusive and confidential property of Continental Conveyor and Machine Works Ltd.

Ce dessin est la propriété confidentielle et exclusive de Convoyeur Continental et Usinage Ltee.

Drawn/Dessiné AH	Checked/Vérifié	Approved/Approuvé	Napaneé Job No./Contrat No.
Date (MM-DD-YYYY) 02-19-2025	Scale/Échelle 1:10	Weight/Poids Net 91.7 Lbs	Thetford Job No./Contrat No.

Identification No.

continental CONVEYOR & MACHINE WORKS LTD.
CONVOYEUR CONTINENTAL & USINAGE LTÉE

THETFORD MINES, QUEBEC, CANADA
NAPANEE, ONTARIO, CANADA

STANDARD

STATION SUPÉRIEURE, TYPE ALIMENTATEUR, AUGE 20°
LARGEUR DE BANDE 48" ROULEAU Ø5-1/4" ARBRE Ø20mm 30,000 SÉRIE

Format: Drawing No./Dessin No.
A BB-33420-5-48

Revision
0