

MATERIAL LIST / LISTE DE MATERIEL

(Designations of pieces in Imperial, dimensions in millimeters unless otherwise specified)
(Désignations des pièces en Impérial, dimensions en millimètre sauf indication contraire)

ITEM NO.	DESCRIPTION	MATERIAL/MATERIEL	QTY/QTE	DRAWING/DESSIN NO. PART/PIECE NO.	WEIGHT/POIDS KG	WEIGHT/POIDS LBS
1	ROULEAU ACIER		3	BBTR520200541A6SC	37.2	81.9
2	SUPPORT DE ROULEAU 35°		1	BBFR30D3560	24.4	53.7
3	FIXATION EXTÉRIEURE		2	BBRCEB20	0.0	0.0
4	VIS AUTO-TARAUEUSE		2	HABSLZINC005NC010	0.0	0.0
5	FIXATION INTÉRIEURE		2	BBRCCB35	0.1	0.2

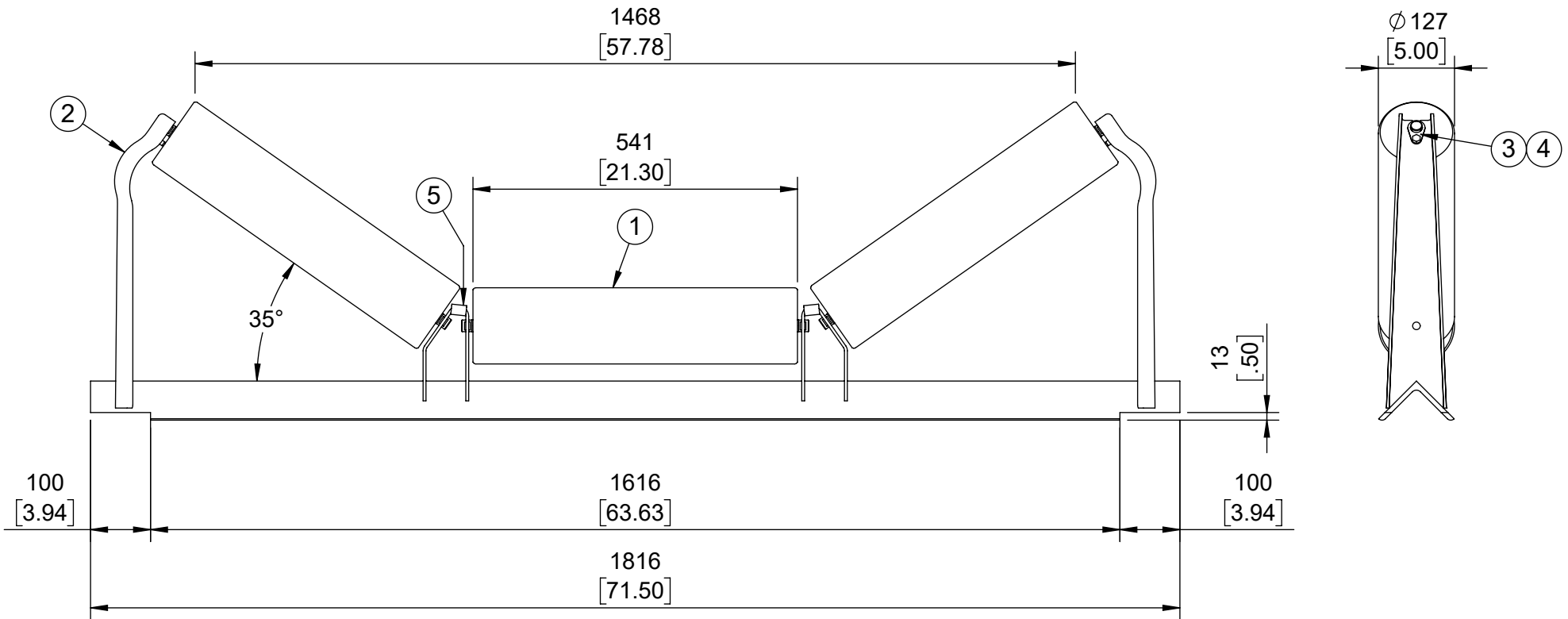

No.	REVISIONS	DATE	BY
0	ÉMIS POUR LA CONSTRUCTION	01-09-2025	AH



DO NOT SCALE
NE PAS PRENDRE À L'ÉCHELLE

DIMENSIONS ARE IN mm [INCHES]

SURFACE FINISH
✓

SURFACE

THIRD ANGLE PROJECTION
PROJECTION TROISIÈME ANGLE

This drawing is the exclusive and confidential property of Continental Conveyor and Machine Works Ltd. Ce dessin est la propriété confidentielle et exclusive de Convoyeur Continental et Usinage Ltee.

Drawn/Dessiné AH	Checked/Vérifié	Approved/Approuvé	Napawee Job No./Contrat No.
Date (MM/DD/YYYY) 01-09-2025	Scale/Échelle 1:10	Weight/Poids Net 135.7 Lbs	Theftford Job No./Contrat No.
Identification No.			

continental CONTINENTAL CONVEYOR & MACHINE WORKS LTD.
CONVOYEUR CONTINENTAL & USINAGE LTÉE

THEFTFORD MINES, QUEBEC, CANADA
NAPANEE, ONTARIO, CANADA

STANDARD

STATION SUPÉRIEURE, TYPE PESEUR, SANS PIED, AUGRE 35°
LARGEUR DE BANDE 60" ROULEAU Ø5" ARBRE Ø20mm 30,000 SÉRIE

Format: A Drawing No./Dessin No. **BB-34D35-5-60** Revision **0**